

# HEATPEX ARIA



**Complete** heat recovery  
ventilation **system**



# HEATPEX / ARIA

COMPLETE MVHR SYSTEM

**ARIA**  
VITALE

3 FLOW RATES:  
300 / 450 / 600 m<sup>3</sup>/h



OR



**ARIA**  
VITALE

COMPACT

2 FLOW RATES:  
250 / 350 m<sup>3</sup>/h

**HEATPEX**  
**ARIA**



**ARIA**  
FLAT500

ULTRA-LOW HEIGHT:  
ONLY 5 cm!

OR



**ARIA**  
ADURO

3 DIAMETERS:  
125 / 160 / 200 mm

**ARIA**  
CONNECT

3 DIAMETERS:  
63 / 75 / 90 mm

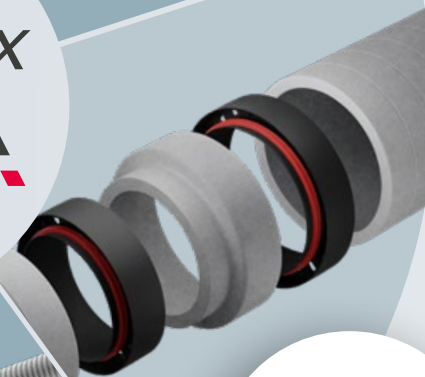



# Table of contents

ARIA PLANNER 2.0	4
MVHR unit selection by property size	6

---

## Mechanical ventilation with heat recovery **ARIA VITALE** and **ARIA VITALE compact** **NEW**

Product range	10
Key features and benefits	12
Design of ARIA VITALE MVHR units	16
Technical specifications	22

---

## **ARIA CONNECT** and **ARIA FLAT 500** **23** air distribution ducting systems

Product range	26
Key features and benefits	28
Components	32
Installation accessories	46

---

## **ARIA ADURO** insulated mass flow ductwork **47**

Key features and benefits	50
Components and accessories	54

**LEARN MORE**  
ABOUT THE HEATPEX  
ARIA SYSTEM ON  
OUR WEBSITE

> **heatpex.pl**

# ARIA PLANNER 2.0



**Plan your heat recovery system in just minutes.** Automatically generate a complete bill of materials.

# 3 SIMPLE STEPS

Design your heat recovery system with ease

**1** Select national calculation standards for your country.

**2** Add individual rooms, specify occupant numbers, define project zoning.

**3** Select connection type: central or side.



Generate your bill of materials instantly.

## Why it's worth it:

- **Clear step-by-step process**
- **Automatic unit selection and airflow balancing** – ensuring balanced supply and extract ventilation
- Compliance with national standards
- Selection of air supply points (air vents) **for each room**

## Additional module for professionals

UPLOAD PLAN

GRAPHIC EDITOR

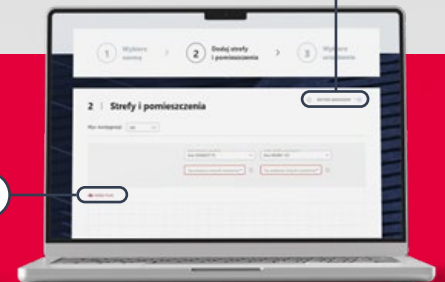

### Discussing project with an investor?

- **Well-prepared design** supports clear communication
- **Structured installation concept**
- **Defined plan** of action

### Additional graphics module (free after login)

- **Create installation drawings** quickly, without specialist software
- More **detailed bill of materials** based on project
- **Complete design documentation** with material list

### Benefits:

- **Time savings** through automation
- **Reduced risk** of design errors
- **Professional documentation** for customer



## Recommended ventilation unit size according to EN-16798 <sup>(1)</sup>

	70 m <sup>2</sup>	80 m <sup>2</sup>	100 m <sup>2</sup>	120 m <sup>2</sup>	160 m <sup>2</sup>	200 m <sup>2</sup>	240 m <sup>2</sup>	320 m <sup>2</sup>	
<b>FLOOR AREA</b>									<b>FLOOR AREA</b>
<b>NO. OF MAIN ROOMS<sup>(2)</sup></b>	3	3	5	6	7	8	9	10	<b>NO. OF MAIN ROOMS</b>
<b>NO. OF BATHROOMS</b>	1	1	2	2	2	3	3	3	<b>NO. OF BATHROOMS</b>
<b>ADDITIONAL WET ROOMS<sup>(3)</sup></b>	0	0	0	1	2	2	2	3	<b>ADDITIONAL WET ROOMS</b>
									
	ARIA VITALE compact 250 m <sup>3</sup> /h	ARIA VITALE compact 250 m <sup>3</sup> /h	ARIA VITALE compact 350 m <sup>3</sup> /h			ARIA VITALE 450 m <sup>3</sup> /h			
									
		ARIA VITALE 300 m <sup>3</sup> /h	ARIA VITALE 450 m <sup>3</sup> /h	ARIA VITALE 450 m <sup>3</sup> /h	ARIA VITALE 450 m <sup>3</sup> /h	ARIA VITALE 600 m <sup>3</sup> /h	ARIA VITALE 600 m <sup>3</sup> /h	ARIA VITALE 600 m <sup>3</sup> /h	

**(1)** Each House has: 1 kitchen, 1 bathroom and 1 toilet in standard **(2)** Main rooms: bedrooms + living rooms **(3)** Additional wet rooms: all rooms with high moisture concentration and all additional toilets. / Floor areas and airflow values shown **for illustration only**. Final unit selection must be based on precise calculations in accordance with applicable national standards.

### ARIA PLANNER 2.0



**For accurate system selection, use ARIA PLANNER 2.0.** Select appropriate unit based on building area and volume. Supports full air distribution system planning. Includes ducts, distribution boxes, valves and required components.



# Mechanical ventilation with heat recovery ARIA VITALE and ARIA VITALE compact

FUNCTIONALITY IN EVERY DETAIL



**NEW**



ARIA  
VITALE  
COMPACT

**NEW**





# Discover **ARIA** **VITALE** MVHR Units – Ideal solution for modern homes

Ventilation – key to healthy living.

**HEATPEX developed ARIA VITALE to deliver high indoor air quality with maximum efficiency.** Designed in line with sustainable building principles, the unit combines durability, functionality and modern design. High-quality components ensure reliable performance and long service life.

**Innovative EPP casing provides:**

- / Lightweight construction
- / Excellent acoustic performance
- / Clean, aesthetic finish
- / Reduced environmental impact

## ARIA VITALE SERIES:

**2 models**

**5 airflow rates**

Distinctive **design**

**Functional** solutions

**Easy installation**

Long-lasting **quality**



# ARIA VITALE

## Heat recovery ventilation unit

MASS

**27.5 kg**



**40% lighter**  
than comparable  
units on market

# A+

H/W/D DIMENSIONS

**900 / 937 / 365 mm**

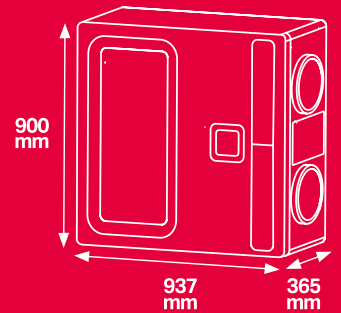

reddot winner 2023



DESIGN  
AWARD  
2023



/// FLOW RATES

**300 / 450 / 600 m<sup>3</sup>/h**

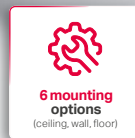

**6 mounting  
options**  
(ceiling, wall, floor)



**Wi-Fi  
Remote control**



**Plug & Play**



**100% bypass**

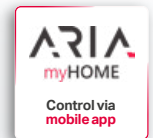

**ARIA  
myHOME**  
Control via  
mobile app

FEATURES

### PLATINUM Enthalpy

Enthalpy heat exchanger  
Temperature sensor  
CO<sub>2</sub> sensor  
Humidity sensor

### PLATINUM<sup>CF</sup> Enthalpy

Enthalpy heat exchanger  
Temperature sensor  
CO<sub>2</sub> sensor  
Humidity sensor  
Constant Flow (CF) function

**ARIA**  
**VITALE**

C O M P A C T

# Compact heat recovery ventilation unit

DIMENSIONS H/W/D

**865 / 520 / 585 mm**

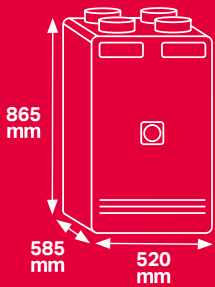

**A+**

MASS

**20 kg**



**40% lighter**  
than comparable  
units on market

IKONA'25  
**DOBRY  
WZÓR**

## FEATURES



/// FLOW RATES

**250 / 350 m<sup>3</sup>/h**

**SILVER**

Temperature sensor

**PLATINUM<sup>CF</sup>**  
Enthalpy

Enthalpy heat exchanger  
Temperature sensor  
CO<sub>2</sub> sensor  
Humidity sensor  
Constant Flow (CF) function

# Mounting options



ceiling



wall



floor



## 6 installation options ARIA VITALE

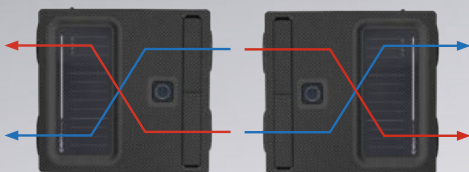

Right- or left-hand installation depending on air intake position - control panel can be rotated

## 4 connection options ARIA VITALE compact

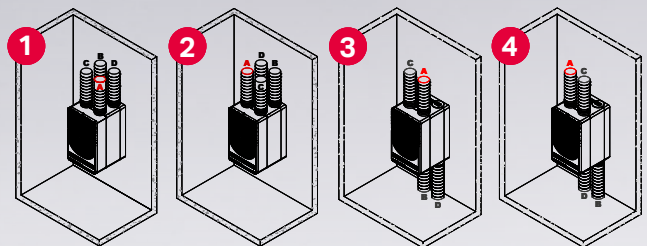

A. Fresh air B. Supply air C. Extract air D. Exhaust air

## Quiet and airtight

ARIA VITALE units feature laser-enhanced **EPP casing** with wall thickness up to **50 mm (40 mm** in ARIA VITALE compact). Thermally bonded EPP structure, increased wall thickness, EPP spigots and optimised hardware configuration form a fully integrated casing system. This design delivers **exceptional airtightness, eliminates thermal bridges and ensures quiet**, stable operation – particularly important for night-time comfort.

# 50

mm

**thickness of  
EPP walls  
in ARIA VITALE**

**Sound pressure  
level from**

# 42.1 dB(A)

## Flexible and **simple installation**

**ARIA VITALE and ARIA VITALE compact packaging** includes custom mounting brackets and built-in spirit levels (ARIA VITALE only). For easier installation, use 1:1 scale mounting template printed on back of packaging.



## Efficient and energy-saving

High-efficiency heat exchangers enable heat recovery of up to 95%. Intelligent control system with weekly programming supports energy savings of up to 30% compared to manual operation.

Quick-access functions such as Holiday Mode reduce unit operation during absence and optimise energy consumption.

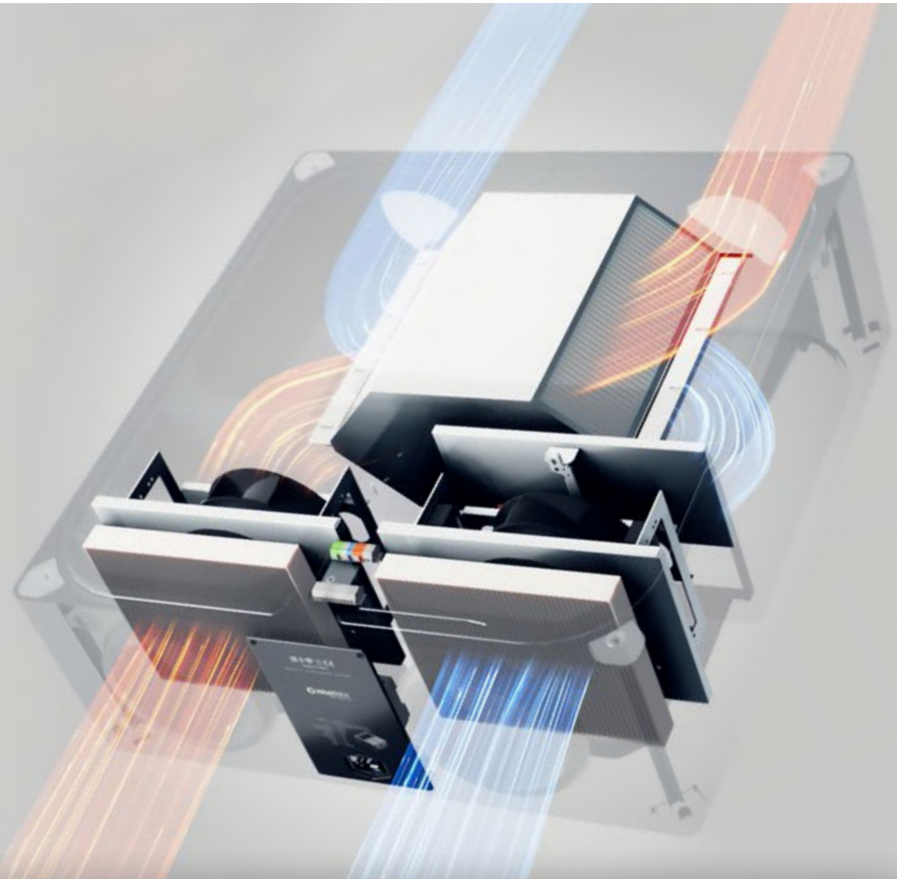

ENERGY EFFICIENCY UP TO

95%

ENERGY SAVINGS UP TO

30%



## Highest indoor air quality for you and your family

ARIA VITALE units are equipped with **high-performance cartridge filters** that protect against smog, bacteria, viruses and pollen.

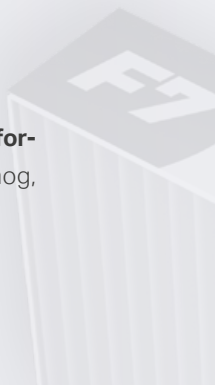

# Antibacterial and antiviral counterflow enthalpy heat exchanger

Counterflow enthalpy exchanger with antibacterial and antiviral membrane. **Protection against viruses (including SARS-CoV-2), bacteria, mould, unpleasant odours and biological pollutants.**

Durable polymer membrane provides:

- **High thermal conductivity** and efficient moisture transfer
- **Resistance** to acids, alkalis and salts for stable long-term operation
- **High tear and puncture resistance**
- **Excellent resistance to environmental influences** and temperature fluctuations (-25°C to +50°C)
- **Low air permeability**



FILTERS FOR ARIA VITALE



FILTERS FOR ARIA VITALE compact



EXTRACT AIR: **M5** ISO PM<sub>10</sub> 50%

FRESH AIR: **F7** ANTI-SMOG FILTER **or** **M5** ACTIVATED CARBON FILTER

**F7** ISO ePM<sub>1</sub> 70% (ePM<sub>1</sub> 73.27% | ePM<sub>2.5</sub> 80.23% | ePM<sub>10</sub> 91.94%) **or** **M5** with activated carbon

# ARIA VITALE

## ARIA VITALE design features

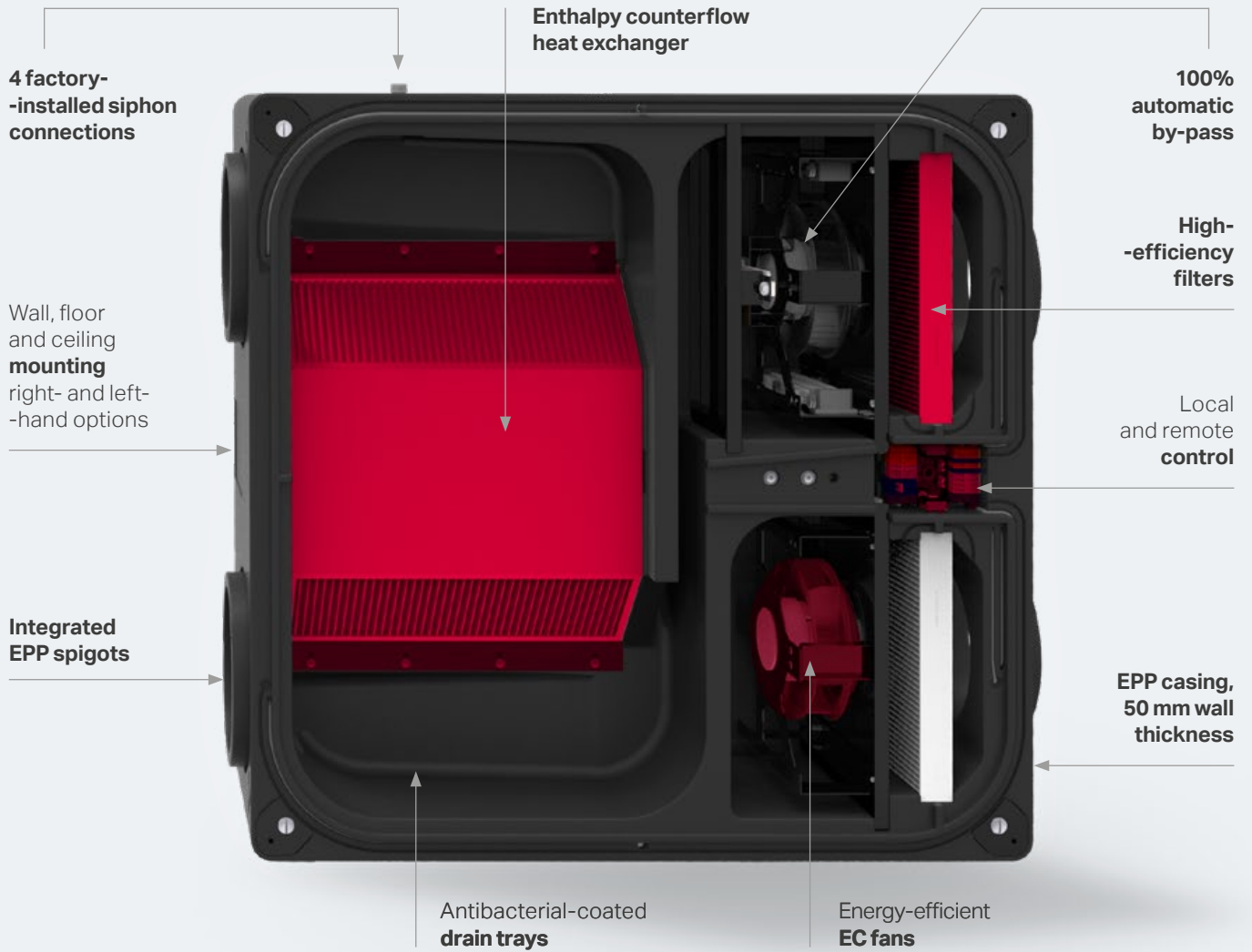

### STANDARD FEATURES OF ARIA VITALE

Wi-Fi / wireless connectivity

Antifrost system with preheater

100% bypass

Flat glass touch screen control panel

Mounting brackets and floor supports



# ARIA VITALE compact design features

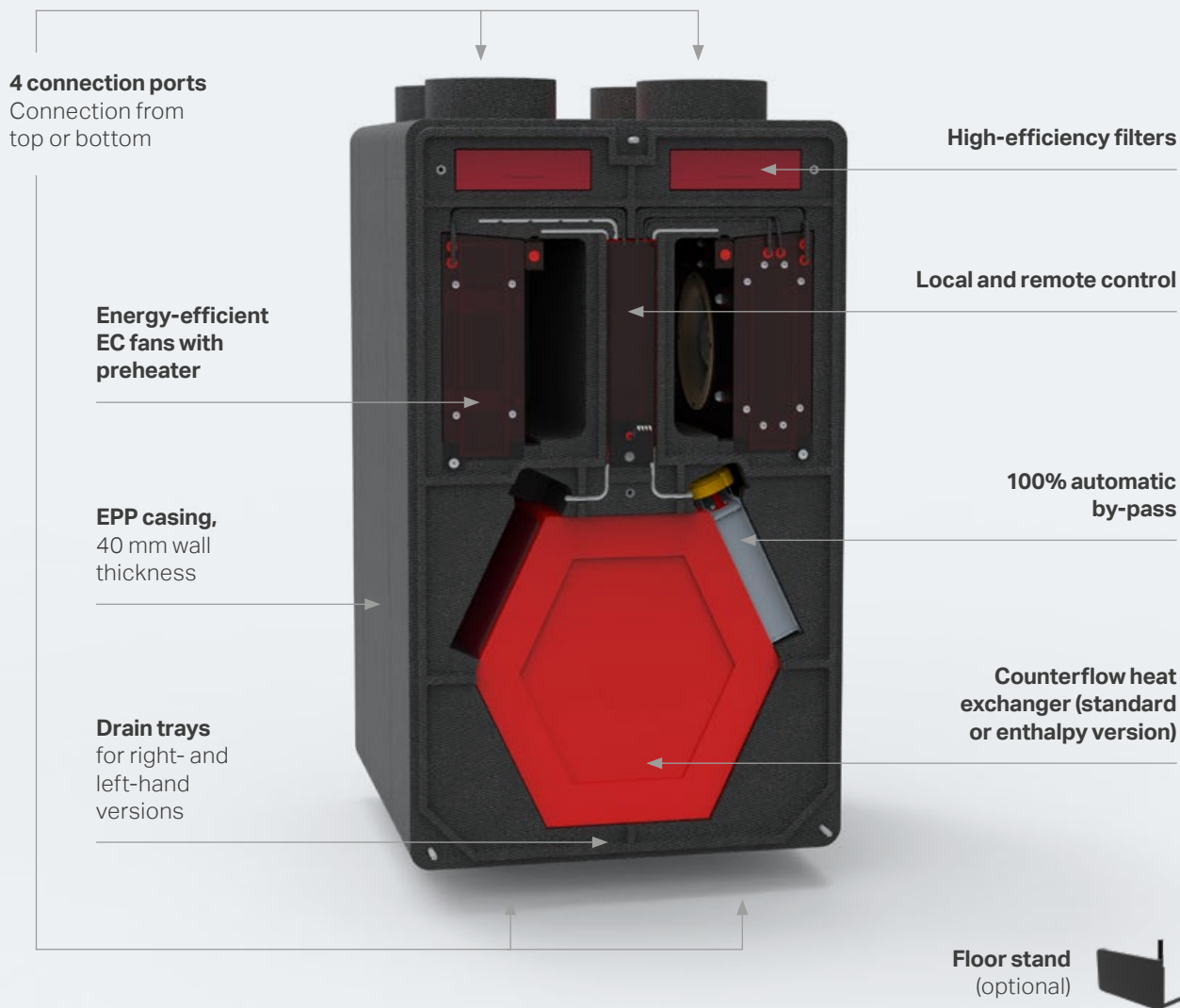

STANDARD FEATURES OF ARIA VITALE compact

Wi-Fi / wireless connectivity

Antifrost system with preheater

100% bypass

Flat glass touch screen control panel

Mounting brackets

## Removable control panel

The glass control panel can be removed from the unit and installed on a wall in a convenient location, such as a living area. Provides easy access to system settings without needing to reach the unit itself – particularly useful when the MVHR unit is installed in an attic, garage or technical room. A dedicated blanking panel is included to replace the control interface on the unit once removed.

### Mounting options

Wall-mounted or Mounted on unit



## Simple & intuitive operation

Pre-defined operating modes



HOLIDAY  
MODE



PARTY  
MODE



AUTOMATIC  
MODE

**Touch control panel with intuitive interface.** Pre-defined operating modes and integrated sensors automatically respond to changing air conditions, optimising comfort, noise level and energy consumption.

# Advanced control

Advanced settings and control options available via **ARIA myHOME app** for smartphones and computers. **Wi-Fi connectivity as standard**. Integration with **Smart Home systems via Modbus RTU** protocol.



## Plug & play philosophy

Connect to power supply – ready to operate.

# Hidden functionalities

**ARIA VITALE** and **ARIA VITALE compact** units include practical, user-focused features.

**1. Washable service note panel**

Record service inspections and filter replacement dates directly on the unit.

**2. Removable control panel**

Control panel can be relocated to wall for convenient daily access.



**3. Functional filter access panels**

Filter covers also serve as storage space for marker pen and basic service tools.



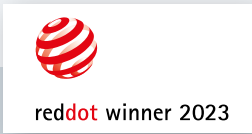

## Timeless **design**

Casing made of laser-enhanced **expanded polypropylene (EPP)** – **lightweight**, **durable** and **highly resistant**. Surface texture enhances **aesthetic appeal**, while integrated grooves add depth and **visual dynamism**. The **refined geometry** makes the unit appear more compact and **visually lighter**.



# Technical specifications

	ARIA VITALE			ARIA VITALE compact	
	300	450	600	250	350
<b>Nominal air flow</b>	300 m <sup>3</sup> /h	450 m <sup>3</sup> /h	600 m <sup>3</sup> /h	250 m <sup>3</sup> /h	350 m <sup>3</sup> /h
<b>Dimensions (H x W x D)</b>	900 mm / 937 mm / 365 mm			865 mm / 520 mm / 585 mm	
<b>Mass</b>	27.5 kg (Platinum) / 29.9 kg (Platinum CF)			20 kg	
<b>Diameter of connections</b>	200 mm			125 mm	
<b>Condensate drain diameter</b>	32 mm			32 mm	
<b>IP protection rating</b>	IP 40			IP 40	
<b>Power supply</b>	230V / 50Hz			230V / 50Hz	
<b>Rated power of fans</b>	2 x 45 W	2 x 95 W	2 x 177 W	2 x 90 W	
<b>Preheater power</b>	1000 W	2000 W	2000 W	500 W	
<b>Filter class</b>	ePM <sub>1</sub> 70% (F7) – supply air ePM <sub>10</sub> 50% (M5) – exhaust air			ePM <sub>1</sub> 70% (F7) – supply air ePM <sub>10</sub> 50% (M5) – exhaust air	
<b>Heat exchanger</b>	Counterflow enthalpy			Counterflow (Silver), counterflow enthalpy (Platinum CF)	
<b>Thermal efficiency of heat recovery</b>	86.5 / 84.2% (CF)	84.7 / 83.1% (CF)	83.9 / 82.3% (CF)	88,3 %	85 %
<b>Compression at nominal flow rate</b>	180 Pa	165 Pa	165 Pa	140 Pa	130 Pa
<b>Housing material</b>	EPP			EPP	
<b>Sensors</b>	Temperature, humidity and CO <sub>2</sub> (Platinum) Temperature, humidity and CO <sub>2</sub> , constant flow (Platinum CF)			Temperature (Silver) / Temperature, humidity and CO <sub>2</sub> , constant flow (Platinum CF)	
<b>Air flow control</b>	Automatic flow regulation and balancing air (Platinum CF) / Traditional, fully smooth fan speed control (Platinum)			Automatic adjustment and balancing of air flows (Platinum CF) / Traditional, fully smooth adjustment of fan rotation speed (Silver)	
<b>100% automatic bypass</b>	YES			YES	
<b>Anti-freeze system with heater</b>	YES			YES	
<b>Wi-Fi / wireless connection</b>	YES			YES	
<b>Factory gear settings</b>	<b>1</b>	<b>2</b>	<b>3</b>	<b>Party mode</b>	<b>Holiday mode</b>
	35%	55%	75%	100%	25%
<b>ARIA VITALE 300 [m<sup>3</sup>/h]</b>	105	165	225	300	75
<b>ARIA VITALE 450 [m<sup>3</sup>/h]</b>	158	248	338	450	113
<b>ARIA VITALE 600 [m<sup>3</sup>/h]</b>	210	330	450	600	150
<b>ARIA VITALE compact 250 [m<sup>3</sup>/h]</b>	88	138	188	250	63
<b>ARIA VITALE compact 350 [m<sup>3</sup>/h]</b>	123	193	263	350	88



ARIA  
CONNECT

ARIA  
FLAT500

# ARIA CONNECT and ARIA FLAT 500 air distribution ducting systems

AIR DISTRIBUTION SYSTEMS  
FOR SINGLE-FAMILY HOUSING

RADIAL SYSTEM

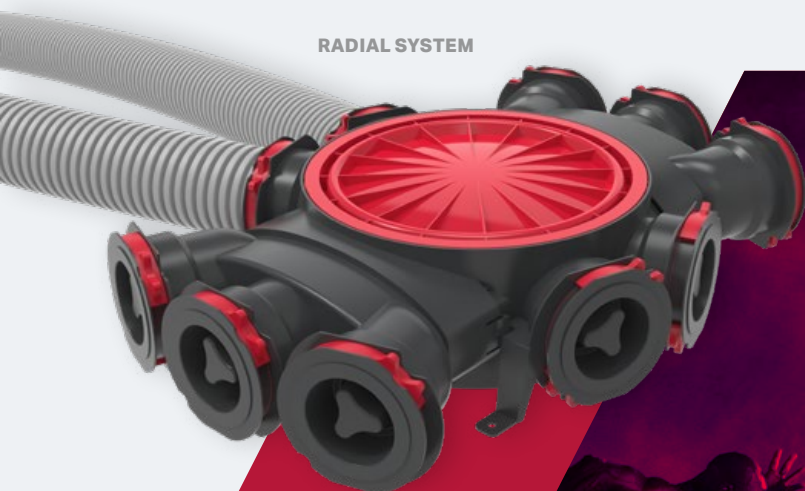

ATC1



100%

ANTIBACTERIAL

ONE<sup>®</sup>  
CLICK  
technology

FLAT SYSTEM

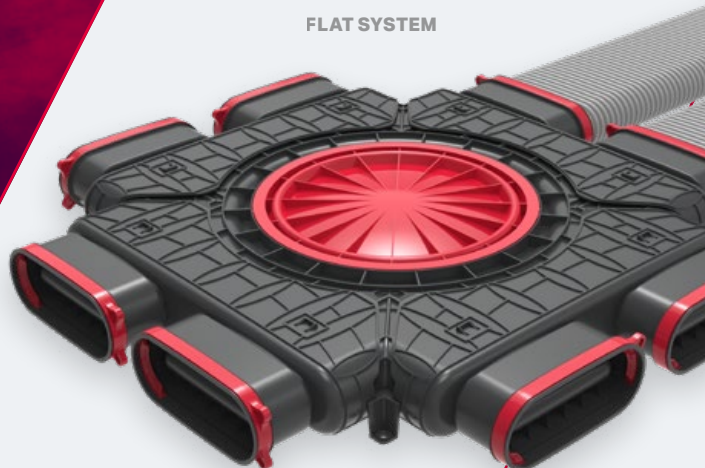



### Optimised airflow throughout the building

Enables precise adjustment of supply and extract air volumes according to the size and function of each room.



### Optimisation of material use and costs

More economical system design thanks to the use of smaller duct diameters where higher airflow rates are not required.

### Expandability and flexible configuration

Different duct diameters and appropriately selected distribution boxes allow easy system expansion or layout modifications without replacing the entire installation.

### Easy and quick installation

Smaller duct dimensions allow easier installation in screed, floors or ceilings – particularly beneficial in low-ceiling residential buildings.



### Flexible installation design

Combination of different diameters allows easy adaptation to building conditions, including limited installation space in ceilings or walls.

# Discover the benefits of **ARIA CONNECT** and **ARIA FLAT 500** air distribution systems

## Heat recovery in single-family homes

HEATPEX offers **modern ventilation and heat recovery distribution systems**: ARIA CONNECT (radial) and ARIA FLAT 500 (flat). ARIA CONNECT features traditional round ducts, while ARIA FLAT 500 uses flat ducts designed for modern interiors where space and aesthetics are important. Both systems are manufactured using **OneClick® technology** for quick and easy installation. System planning is simplified with the **free ARIA PLANNER selection software**, which automatically calculates material requirements.

### Both systems provide:

- / Energy-efficient installation
- / Clean and hygienic air supply
- / High user comfort
- / Proprietary OneClick® technology ensures fast, tool-free assembly.
- / ATC1 airtightness class guarantees low operating costs.
- / Ultra-Fresh® technology eliminates up to 99.9% of bacteria from the air, supporting a healthy indoor environment.

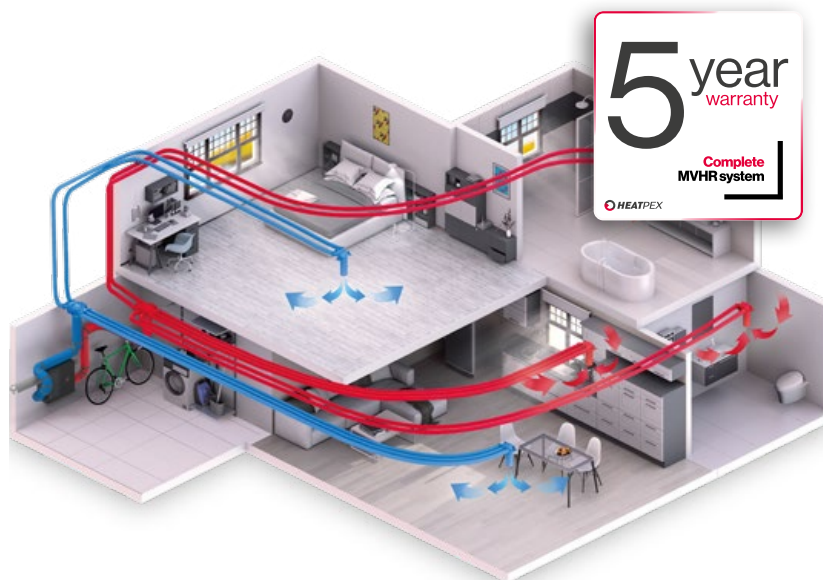

# ARIA CONNECT

## Radial system

Multiple diameters, one unified solution



Complete air distribution system:

only **6** basic components

### Boxes



### Connectors



### Couplings



Semi-rigid ventilation duct

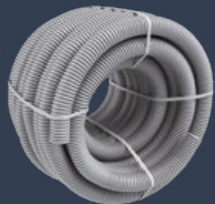

L=50m



# Flat system

Expanded possibilities

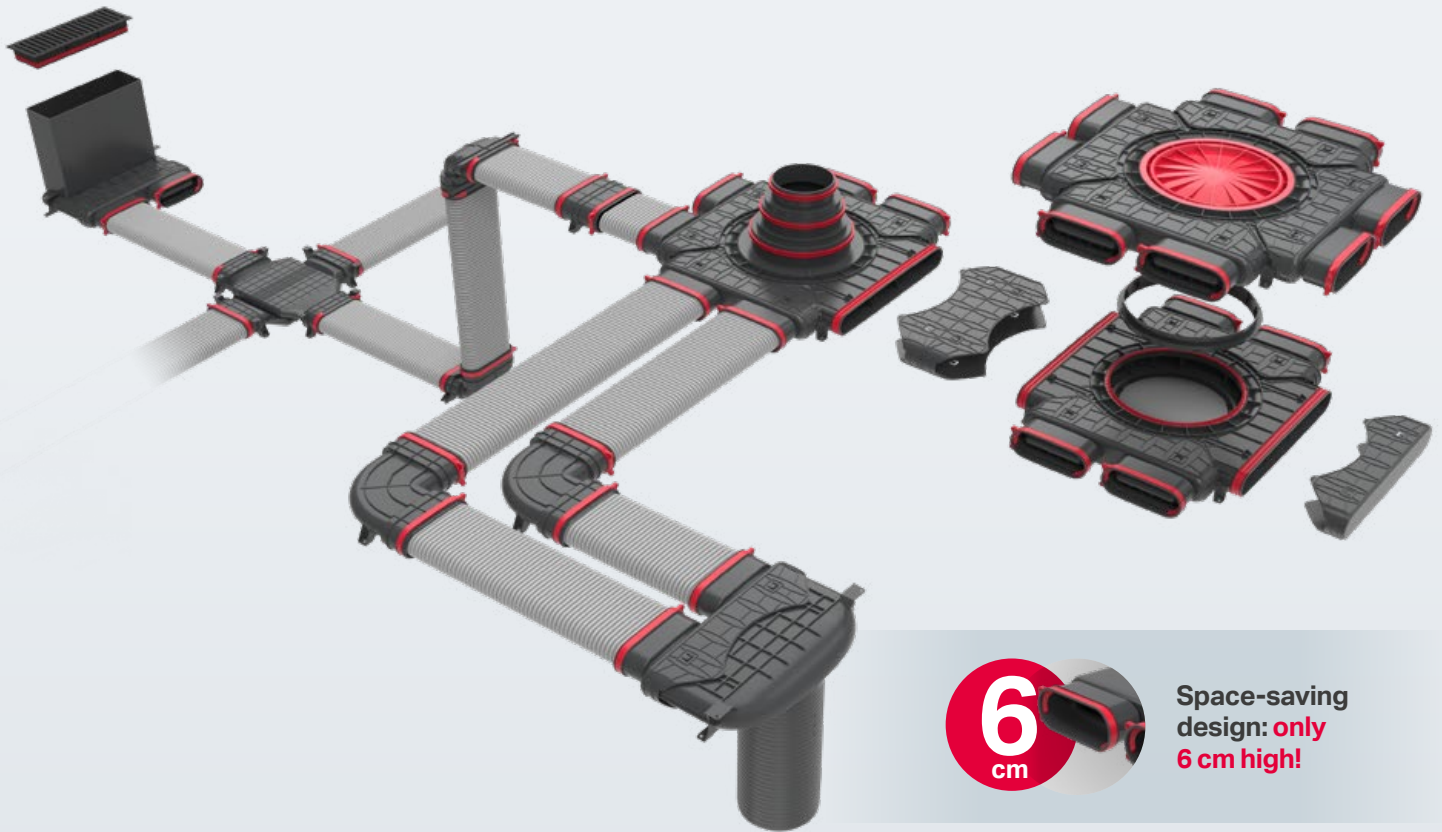

**6**  
cm

Space-saving design: **only 6 cm high!**

**Combine radial and flat systems for total flexibility**

Installation made easy: **Everything clicks into place!**

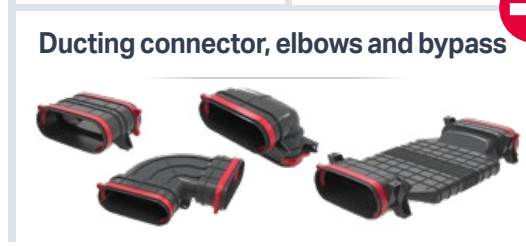
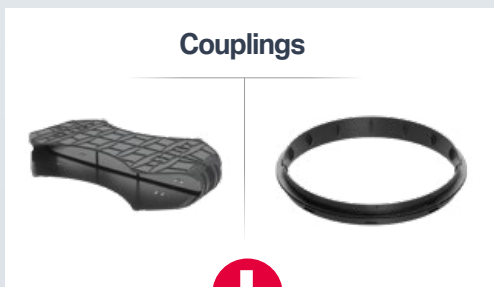
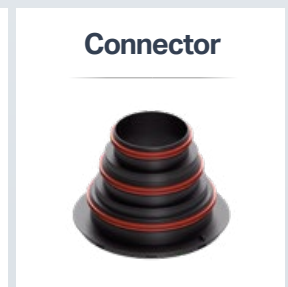

# Modular design, **total flexibility**

**ARIA  
CONNECT**



**ARIA  
FLAT500**



### Vertical connection

(Modular design allows for multiple box configurations)

- 63 mm system**  
24 connections
- 75 mm system**  
20 connections
- 90 mm system**  
16 connections

System  
**ARIA FLAT 500**  
16 connections



OR



### Horizontal connection

(Modular design allows for multiple box configurations)

- 63 mm system**  
16 connections
- 75 mm system**  
14 connections
- 90 mm system**  
12 connections

System  
**ARIA FLAT 500**  
12 connections

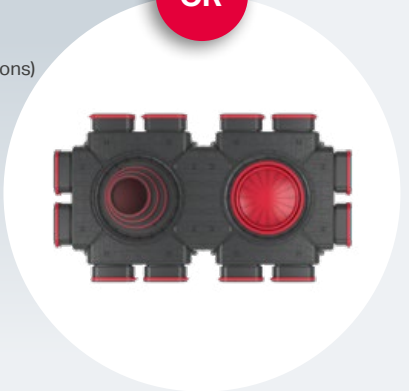

OR

**2 options for connecting the radial and flatduct systems**

OPTION 1: using distribution boxes



OPTION 2: using 75 mm-flat or 90 mm-flat converters



Installation **faster**  
than ever before



**OneClick® technology:**  
Intuitive assembly,  
engineered for speed

OneClick® technology is a proprietary connection system developed by HEATPEX. It allows all heat recovery **components to be joined without tools**. Should your plans change during installation, **parts can be easily disconnected and reused with no risk of damage**.

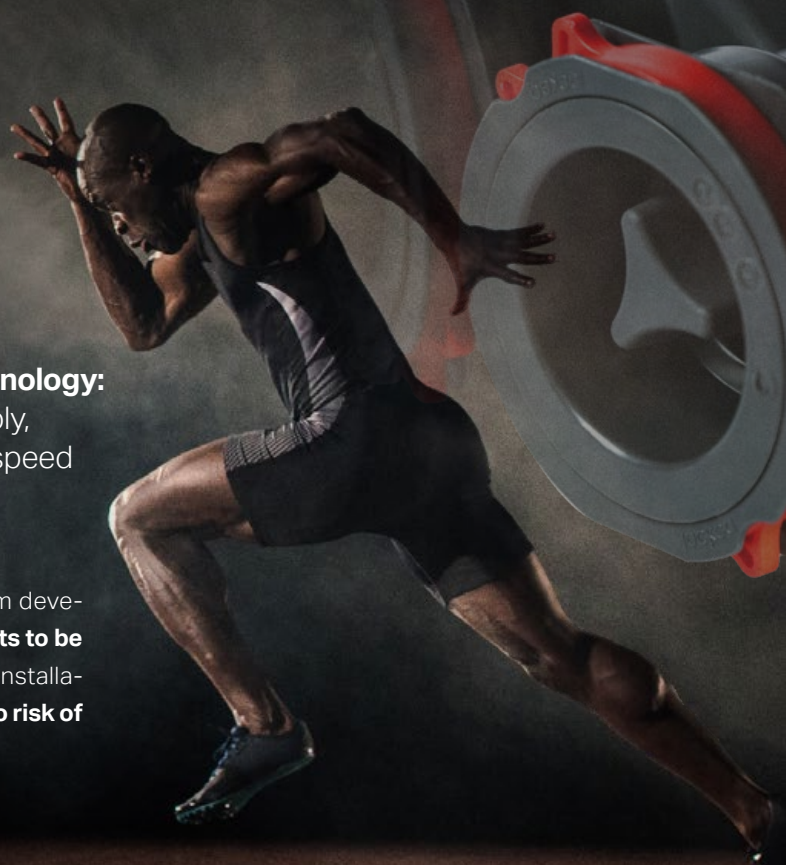

EN 17192

**Highest** airtightness  
rating (ATC 1)

**Quiet, energy-efficient**  
**performance**

Patented OneClick® technology ensures **highest tightness class – ATC 1 per EN 17192**. Delivers **three times higher airtightness** than Class D. Superior seal **achieved without additional tapes or sealants**. **Only system on market** meeting this stringent standard since 2019. Verified by **independent laboratory testing**. Ensures **whisper-quiet operation and maximum energy savings** for end-user.



**ATC1**

## Low pressure losses and low noise levels

Carefully engineered system components and **smooth inner duct surfaces** minimise pressure losses.



Optimised airflow distribution and **double-wall ducts reduce noise generated by moving air** – particularly important during night-time operation.



## Antibacterial protection as standard

### Clean, fresh air – every day

HEATPEX ARIA ducts and system components are manufactured using **Ultra-Fresh® antibacterial additive**. Ensures **99.9% antibacterial activity**, confirmed by independent laboratory testing in accordance with **ISO 22196**. Phosphate-silver glass-based technology, used in over 300 global brands. **Smooth internal duct surfaces minimise accumulation of contaminants.**



**100%**  
**ANTIBACTERIAL  
PROTECTION**





## Durability & strength

System components manufactured from **durable, lightweight polypropylene (PP)**, ensuring **long-term reliability without risk of corrosion or mechanical damage**.

Ducts, distribution boxes and connectors **suitable for installation in concrete**. Important: **Polypropylene (PP) is considered a health-safe material and is 100% recyclable**.



## Compact size

Compact dimensions of ARIA CONNECT and ARIA FLAT 500 systems **allow installation within ceiling insulation, roof structures or suspended ceilings**.



Only **9.5 cm**  
PLENUM  
BOX HEIGHT

Only **10.6 cm**  
DISTRIBUTION  
BOX HEIGHT

ARIA CONNECT RADIAL SYSTEM

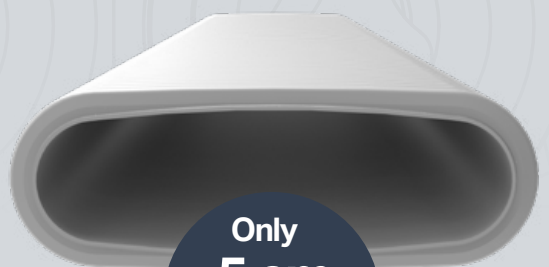

Only **5 cm**  
FLAT  
CHANNEL  
HEIGHT

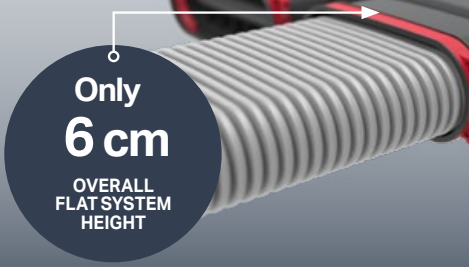

Only **6 cm**  
OVERALL  
FLAT SYSTEM  
HEIGHT

ARIA FLAT 500 FLAT SYSTEM

● **FLAT 500 SYSTEM**

# ARIA FLAT 500 flat system distribution box

**NEW**

Distribution box with OneClick® technology, designed for connection to the heat recovery unit. A complete ventilation system consists of at least two boxes: supply box – distributes fresh air to rooms and extract box – collects stale air.

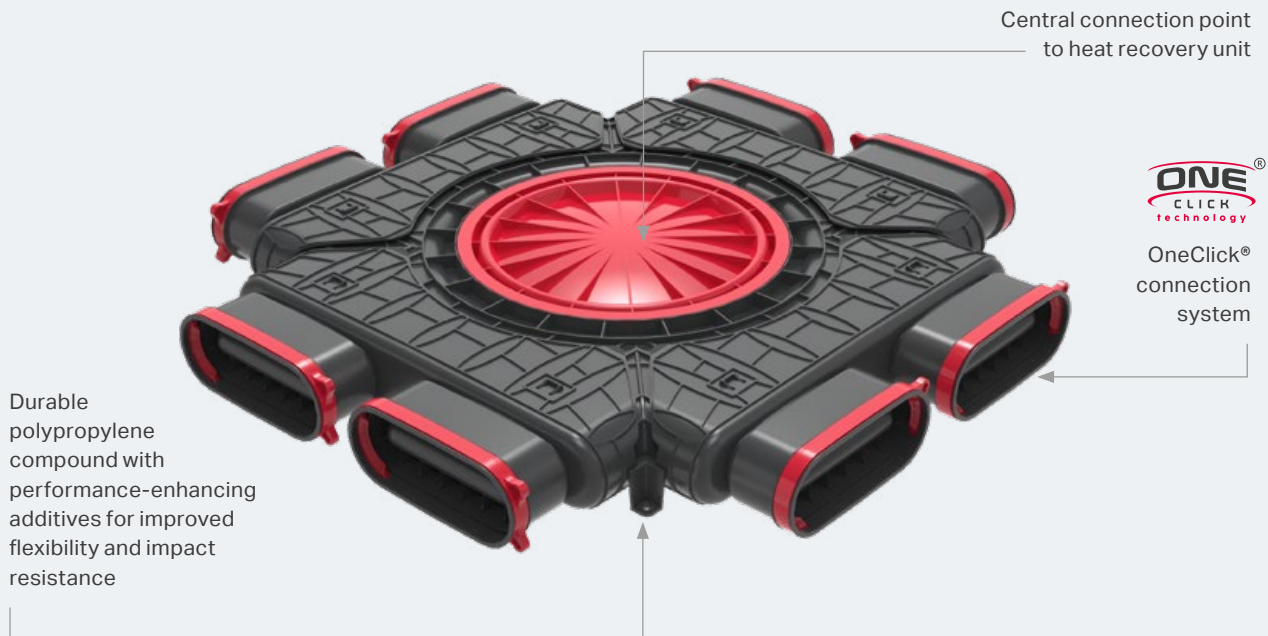

**Vertical connection**

16 connections

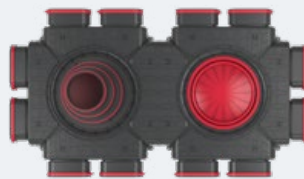

**Horizontal connection**

12 connections



**Flat and radial system integration**

System	Length	Width	Height	Number of 50 mm connections	Mass	Material	Airtightness class	Catalogue number
FLAT 500	573 mm	573 mm	62 mm	8	1.63 kg	PP	ATC1	54000000101W

Supplied fully assembled with factory-fitted plugs and seals. Securely packaged. All unused ports must remain sealed to maintain airtightness.

● RADIAL SYSTEM 63 mm / 75 mm / 90 mm

# ARIA CONNECT radial system distribution box

Central connection point  
to heat recovery unit



OneClick®  
connection  
system

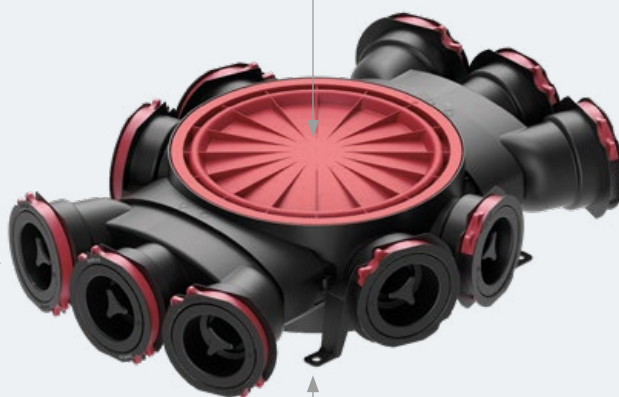

Durable polypropylene compound with performance-enhancing  
additives for improved flexibility and impact resistance



### Vertical connection

63 mm system – 24 connections  
75 mm system – 20 connections  
90 mm system – 16 connections



### Horizontal connection

63 mm system – 16 connections  
75 mm system – 14 connections  
90 mm system – 12 connections



SYSTEM  
63  
mm



SYSTEM  
75  
mm



SYSTEM  
90  
mm



### Flat and radial system integration

System	Length	Width	Height	Number of connections	Mass	Material	Airtightness class	Catalogue number
63 mm	532 mm	421 mm	106 mm	12	1.56 kg	PP	ATC1	52306300100W
75 mm	498 mm	360 mm	106 mm	10	1.47 kg	PP	ATC1	52300000100W
90 mm	522 mm	470 mm	106 mm	8	1.85 kg	PP	ATC1	52309000100W

Supplied fully assembled with factory-fitted plugs and seals. Securely packaged. All unused ports must remain sealed to maintain airtightness.

● FLAT 500 SYSTEM

# ARIA FLAT 500 flat system plenum boxes

Plenum box with OneClick® technology, designed for connection of supply or extract diffusers.

## For linear diffusers

## For round diffusers



SUITABLE FOR INSTALLATION:  
 · IN CEILING INSULATION  
 · WITHIN FLOOR BUILD-UP  
 · IN SUSPENDED CEILINGS



System	Type of box	Length	Width	Height	Number of connections	Mass	Material	Airtightness class	Catalogue number
FLAT 500	Plenum	258 mm	380 mm	361 mm	2	0.91 kg	PP	ATC1	54012500001W
FLAT 500	Linear plenum	271 mm	337 mm	300 mm	2	0.30 kg	PP	ATC1	54030010001W

Supplied fully assembled with factory-fitted plugs and seals. Securely packaged. All unused ports must remain sealed to maintain airtightness.

● RADIAL SYSTEM 63 mm / 75 mm / 90 mm

# ARIA CONNECT radial system plenum boxes

For **linear** diffusers

For **round** diffusers



**SUITABLE FOR INSTALLATION:**

- IN CEILING INSULATION
- WITHIN FLOOR BUILD-UP
- IN SUSPENDED CEILINGS



System	Type of box	Length	Width	Height	Average approach under anemostat (internal)	Number of connections	Mass	Connector length 125 mm	Material	Airtightness class	Number catalogue
63 mm	Plenum	265 mm	349 mm	446 mm	125 mm	4	0.86 kg	349 mm	PP	ATC1	52346300100W
63 mm	Linear plenum	271 mm	337 mm	300 mm	125 mm	4	1.15 kg	349 mm	PP	ATC1	52346300400W
75 mm	Plenum	248 mm	315 mm	447 mm	125 mm	3	0.75 kg	349 mm	PP	ATC1	52337500100W
75 mm	Linear plenum	271 mm	337 mm	300 mm	125 mm	3	1.15 kg	349 mm	PP	ATC1	52337500400W
90 mm	Plenum	263 mm	315 mm	447 mm	125 mm	2	0.78 kg	349 mm	PP	ATC1	52329000100W
90 mm	Linear plenum	271 mm	337 mm	300 mm	125 mm	2	1.15 kg	349 mm	PP	ATC1	52329000400W

Supplied fully assembled with factory-fitted plugs and seals. Securely packaged. All unused ports must remain sealed to maintain airtightness.

● RADIAL SYSTEM 63 mm / 75 mm / 90 mm

● FLAT 500 SYSTEM

# Central main connection

## For radial and flat systems

Central connector for primary supply or extract duct (Ø 125 / 160 / 200 mm) to the distribution box. Compatible with ARIA ADURO insulated mass flow ducts. Allows use of both round and flat duct systems and ensures efficient transfer of high air volumes to and from the MVHR unit.



**Mounted directly to main socket of the distribution box.** / Supports duct diameters: Ø 125 / 160 / 200 mm (with seals included), Ø 150 / 180 mm (without seals) / Seals included for 125, 160 and 200 mm connections in both round and flat systems. / Compatible with intermediate spigots for Ø 150 and Ø 180 mm systems (without seals), SPIRO and other standard radial ducts.

System	Height	Maximum diameter	Material	Mass	Airtightness class	Catalogue number
63 / 75 / 90 mm / FLAT 500	171 mm	249 mm	PP	0.29 kg	ATC1	52410900100W

● RADIAL SYSTEM 63 mm / 75 mm / 90 mm

## Side main connection 125/160

### For radial system

Side connector for primary supply or extract duct Ø 125 / 160 mm. Compatible with ARIA ADURO insulated mass flow ducts. Designed to transfer high air volumes to and from the MVHR unit.



Installed in the elliptical socket of the distribution box in place of a 3 × 75 mm or 2 × 90 mm module. / Includes seals for Ø 125 and Ø 160 mm connections to ensure airtight and secure installation. / Compatible with SPIRO and other standard radial ducts.

System	Length	Width	Height	Material	Mass	Airtightness class	Catalogue number
63 / 75 / 90 mm	284 mm	216 mm	167 mm	PP	0.26 kg	ATC1	52411000100W

● RADIAL SYSTEM 63 mm / 75 mm / 90 mm

● FLAT 500 SYSTEM

# Vertical coupling

For **radial** and **flat** systems

Coupling for vertical connection of two or more distribution boxes.

Integrated grip  
tabs for easier  
installation



**Mounted in the central socket of the distribution box, with universal compatibility: Ø 63 / 75 / 90 mm systems and FLAT 500. /**

Vertical stacking increases available connections: Ø 63 mm system – 24 connections, Ø 75 mm system – 20 connections, Ø 90 mm system – 16 connections / Supplied with integrated plugs for easy installation. / Airtightness class: ATC1 (PN-EN 17192)

System	Type	Length	Width	Height	Material	Mass	Airtightness class	Catalogue number
63 / 75 / 90 mm / FLAT 500	Vertical coupling	249 mm	249 mm	31 mm	PP	0.06 kg	ATC1	52411200100W

● RADIAL SYSTEM 63 mm / 75 mm / 90 mm

● FLAT 500 SYSTEM

# Horizontal coupling and end cap

For **radial** and **flat** systems

Coupling for horizontal connection of two or more distribution boxes.

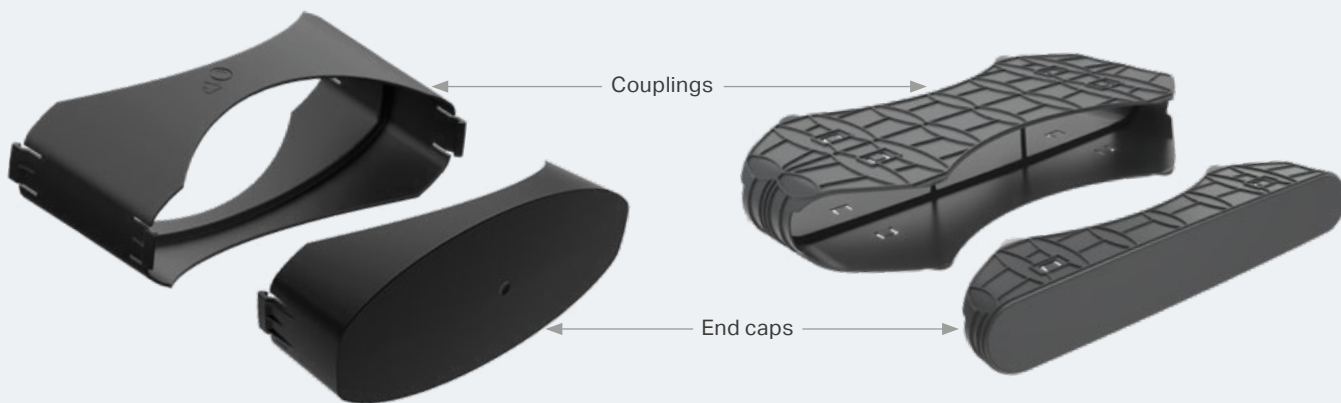

## Radial system



## Flat system



System	Type	Length	Width	Height	Material	Mass	Airtightness class	Catalogue number
63 / 75 / 90 mm	Horizontal coupling	216 mm	110 mm	92 mm	PP	0.07 kg	ATC1	52411100100W
FLAT 500	Horizontal coupling	360 mm	195 mm	62 mm	PP	0.185 kg	ATC1	54011100100W
System	Type	Width	Height	Depth	Material	Mass	Airtightness class	Catalogue number
63 / 75 / 90 mm	Distribution box end cap for wall mounting	212 mm	92 mm	55 mm	PP	0.06 kg	ATC1	52001100100W
FLAT 500		99 mm	363 mm	62 mm	PP	0.13 kg	ATC1	54001100100W

● FLAT 500 SYSTEM

# Antibacterial and antistatic flat ducting and connectors

NEW

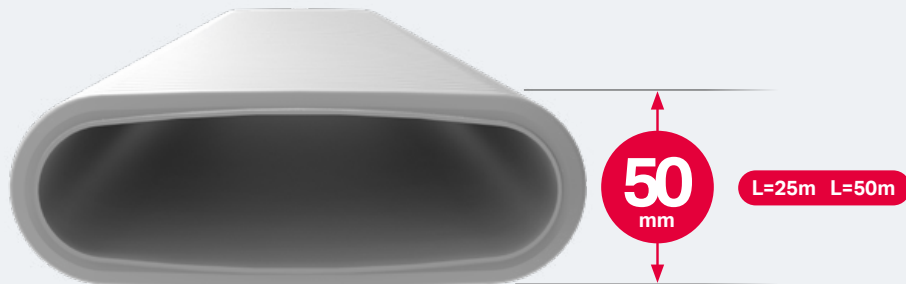

Flat ducting connector

Vertical elbow

Horizontal elbow

Crossing connector for intersecting ducts or passing over building services



System	Type	Width	Height	Coil length	Material	Mass	Airtightness class	Catalogue number
FLAT 500	Flat ducting	141 mm	50 mm	25 m	PE-HD	0.437 kg/m	ATC1	52050002500W
FLAT 500	Flat ducting	141 mm	50 mm	50 m	PE-HD	0.437 kg/m	ATC1	52050005000W
System	Type	Length	Width	Height	Material	Mass	Airtightness class	Catalogue number
FLAT 500	Flat ducting connector	176 mm	114 mm	60 mm	PP	0,144 kg	ATC1	54013300100W
FLAT 500	Vertical elbow	183 mm	120 mm	122 mm	PP	0,154 kg	ATC1	54013500100W
FLAT 500	Horizontal elbow	231 mm	231 mm	60 mm	PP	0,224 kg	ATC1	54013400100W
FLAT 500	Crossing connector	384 mm	200 mm	60 mm	PP	0,128 kg	ATC1	54013600100W
FLAT+75 mm	75 mm-flat converter	155 mm	185 mm	95 mm	PP	0,150 kg	ATC1	54052307500W
FLAT+90 mm	90 mm-flat converter	175 mm	185 mm	105 mm	PP	0,160 kg	ATC1	54052309000W

 Each connector supplied with two seals to ensure airtight installation.

● RADIAL SYSTEM 63 mm / 75 mm / 90 mm

## Antibacterial and antistatic radial ventilation ducting



63 mm

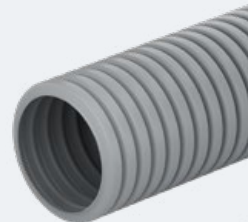

75 mm

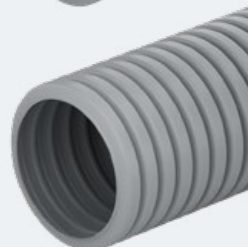

90 mm

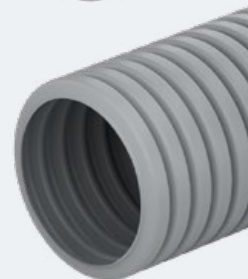

**Ultra-Fresh® antibacterial inner layer with 99.99% efficiency.** / Antistatic properties reduce dust and contaminant build-up. / **High flexibility and impact resistance** (compression strength up to 500 N). / **Smooth internal surface** minimises airflow resistance. / **Low noise emission.** / Highest airtightness class – **ATC1 (PN-EN 17192).**

System	Dimensions			Material	Mass	Airtightness class	Catalogue number
	External diameter	Internal diameter	Coil length				
63 mm	64 mm	52 mm	50 m	PE-HD	0.240 kg/m	ATC1	52006305000W
75 mm	76 mm	63 mm	50 m	PE-HD	0.273 kg/m	ATC1	52007505000W
90 mm	91 mm	75 mm	50 m	PE-HD	0.400 kg/m	ATC1	52009005000W

● RADIAL SYSTEM 63 mm / 75 mm / 90 mm

● FLAT 500 SYSTEM

# Supply and extract air diffusers 125 mm damper / silencer

Polyethylene foam damper with integrated noise attenuation. Regulates airflow within the ventilation system and prevents unintended adjustment.



Type	Nominal diameter of the flange	External diameter	Height	Material	Mass	Catalogue number
Supply air damper	125 mm	160 mm	60 mm	Steel	0.5 kg	52002100100W
Extract air damper	125 mm	160 mm	60 mm	Steel	0.5 kg	52002200100W
Type	Diameter	Height	Material	Mass	Catalogue number	
125 mm damper / silencer	128 mm	50 mm	EVA	0.05 kg	52002400100W	

● RADIAL SYSTEM 63 mm / 75 mm / 90 mm

● FLAT 500 SYSTEM

# Linear supply and extract grilles

Universal grille for wall or floor installation. Slots can be arranged vertically or horizontally to suit design and airflow requirements.

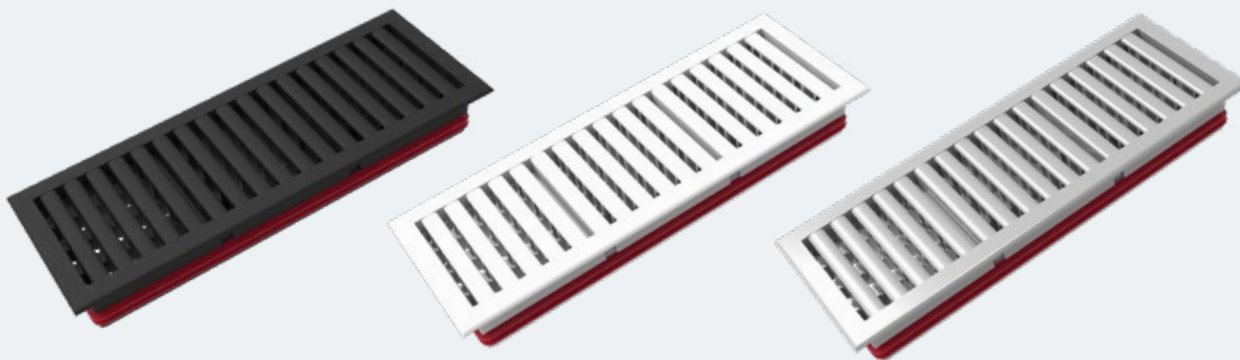

## SAMPLE ARRANGEMENTS

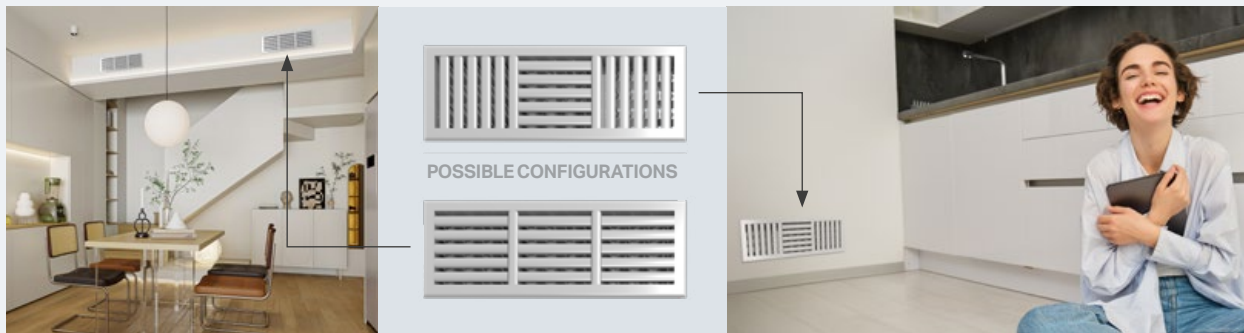

**Universal installation:** wall or floor / **Mounted in linear plenum box** – ARIA CONNECT (63 / 75 / 90 mm) or ARIA FLAT 500 / Adjustable **integrated damper** for airflow control

System	Colour	Length	Width	Height	Material	Mass	Catalogue number
63 / 75 / 90 mm / FLAT 500	Black	315 mm	115 mm	40 mm	ABS	0.2 kg	52040010000W
	White	315 mm	115 mm	40 mm	ABS	0.2 kg	52040020000W
	Silver	315 mm	115 mm	40 mm	ABS	0.2 kg	52040030000W

● RADIAL SYSTEM 63 mm / 75 mm / 90 mm

● FLAT 500 SYSTEM

# ARIA CONNECT and ARIA FLAT 500 system components (available separately)



**63 mm distribution box body**

Catalogue number  
52414100100W



**75 mm distribution box body**

Catalogue number  
52410100100W



**90 mm distribution box body**

Catalogue number  
52413100100W



**63 / 75 / 90 mm plenum box body**

Catalogue number  
52410500100W

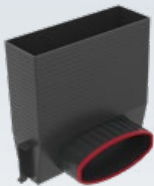

**Linear plenum box body**

Catalogue number  
52410500400W



**Double-socket ducting connector with a set of 2 gaskets**

Catalogue number  
(63 mm) 52011600100W  
(75 mm) 52011200100W  
(90 mm) 52011500100W



**Gasket for radial ducting**

Catalogue number  
(63 mm) 52011700100M  
(75 mm) 52002000100M  
(90 mm) 52011400100M

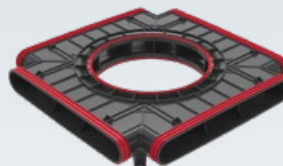

**Flat distribution box body**

Catalogue number  
54013700100W



**Flat plenum  
box body**

---

**Catalogue number**  
54013800100W

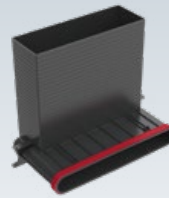

**Linear plenum  
box body**

---

**Catalogue number**  
54013800400W



**Gasket for  
flat ducting**

---

**Catalogue number**  
50000000014M

● RADIAL SYSTEM 63 mm / 75 mm / 90 mm

# Mounting accessories

**Simple and quick clip-on connection**

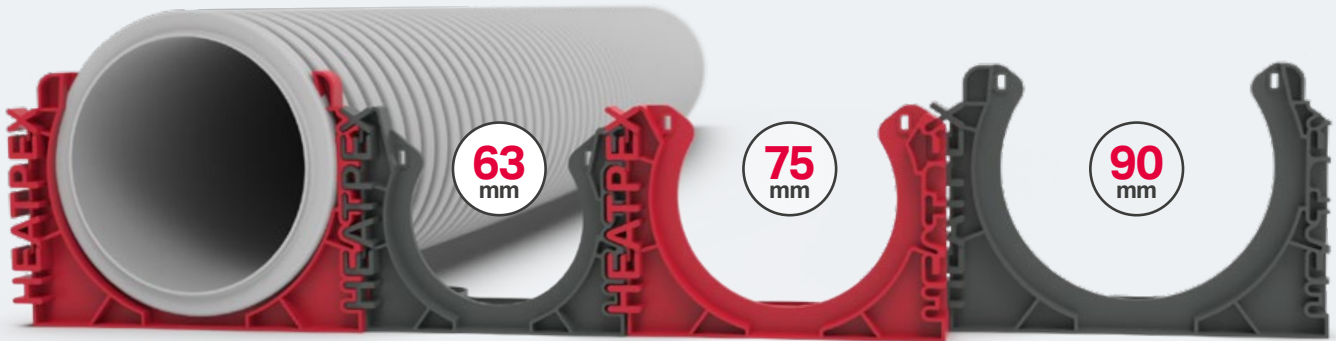

Type	Name	Catalogue number		
	Ventilation duct cutter – 63 mm	52011800100W		
	Ventilation duct cutter – 75 mm	52011900100W		
	Ventilation duct cutter – 90 mm	52012000100W		
<span style="border: 1px solid black; border-radius: 50%; padding: 2px 5px;">63</span>	Ventilation duct clips Red – 63 mm	48 x 83 x 66 mm	10 pieces	52012401000W
			100 pieces	52012410000W
	Ventilation duct clips Grey – 63 mm		10 pieces	52012301000W
			100 pieces	52012310000W
<span style="border: 1px solid black; border-radius: 50%; padding: 2px 5px;">75</span>	Ventilation duct clips Red – 75 mm	48 x 95 x 66 mm	10 pieces	52012501000W
			100 pieces	52012510000W
	Ventilation duct clips Grey – 75 mm		10 pieces	52012101000W
			100 pieces	52012110000W
<span style="border: 1px solid black; border-radius: 50%; padding: 2px 5px;">90</span>	Ventilation duct clips Red – 90 mm	48 x 108 x 76 mm	10 pieces	52012601000W
			100 pieces	52012610000W
	Ventilation duct clips Grey – 90 mm		10 pieces	52012201000W
			100 pieces	52012210000W

Red and grey clips are used to distinguish between supply and extract ducts.



# ARIA ADURO insulated mass flow ductwork for heat recovery installations

UNIVERSAL SYSTEM

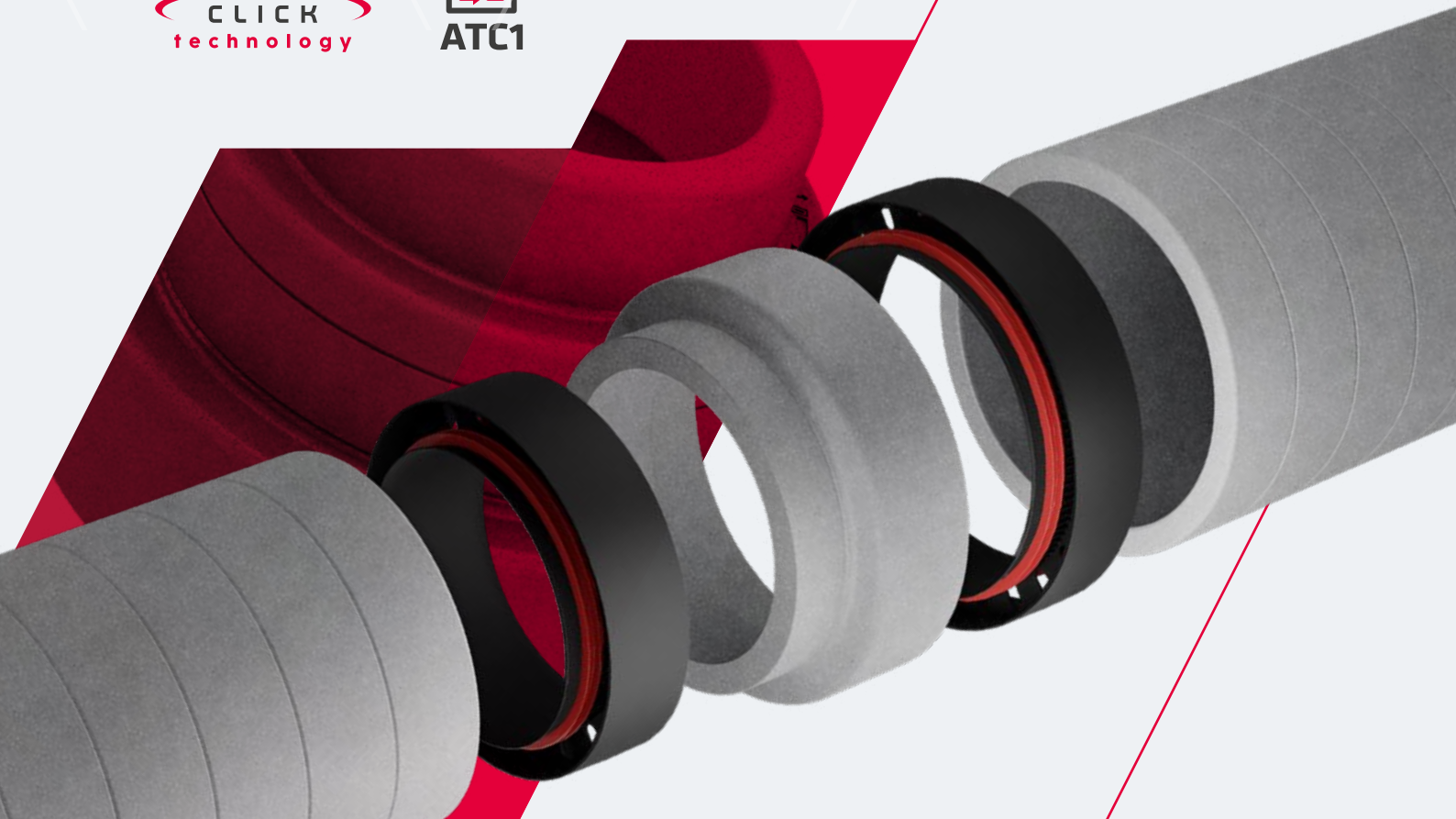



## Discover how **ARIA ADURO** delivers peace of mind and comfort

Insulated mass flow ductwork for heat recovery: **ultra-lightweight, extremely durable, highly practical**

ARIA ADURO insulated ducting is **designed to transfer large air volumes between intake or exhaust terminals and the MVHR unit**, and between the unit and the air distribution box. **Manufactured from lightweight expanded polystyrene (EPS) with graphite additive, providing:**

- / Excellent thermal insulation** ( $\lambda = 0.029 \text{ W/mK}$ )
- / Resistance to mould, fungi and bacteria**
- / Reduced heat loss**

The material and patented **OneClick® connection system** ensure the highest airtightness class – **ATC1 (EN 17192)**, verified by independent laboratory testing. ARIA ADURO is up to **9 times lighter than traditional metal duct systems**, simplifying transport and installation.





# ATC1

HIGHEST AIR TIGHTNESS CLASS

## Highest airtightness

Premium materials, patented OneClick® connection system and optimised component design ensure the **highest airtightness class – ATC1** in accordance with **PN-EN 17192**, verified by independent laboratory testing. **Up to 3 times higher airtightness** compared to Class D systems. High airtightness is achieved thanks to the ARIA ADURO duct design – a **monolithic single-piece body combined with a gasket-sealed connector**. Low-profile connectors do not increase overall installation diameter.

\* When installing ARIA ADURO in cold zones such as unheated attics (ambient temperature below 0°C), additional insulation of the entire system is recommended to prevent condensation. Minimum recommended additional insulation thickness: 50 mm. Final insulation thickness should be determined according to the local climate zone.

# $\lambda = 0.029$ (W/mK)

ARIA ADURO is manufactured from **lightweight, durable EPS with graphite additive, providing excellent thermal performance.**

#### Graphite-enhanced structure ensures:

- / Significant **improvement in thermal insulation** ( $\lambda = 0.029$  W/mK)
- / **Resistance** to mould, fungi and bacteria
- / **Reduced heat loss**
- / **Protection** against internal and external condensation
- / Compared to metal ducts insulated with mineral wool, ARIA ADURO offers **substantially improved insulation efficiency.**





## Universal system

3 diameters: 125 mm / 160 mm / 200 mm



**Reducer** with cut-to-size steps for 125 / 160 / 200 mm



**125**  
mm

**160**  
mm

**200**  
mm



## Original mounting brackets for quick

Fix the patented bracket to the surface, position the duct and secure it with the clamp. **The lightweight construction** reduces the number of fixing points required. **Modular design** allows brackets to be connected in series or side-by-side, enabling **parallel routing of multiple ducts**. One **bracket fits all diameters: 125, 160 and 200 mm**.



**5 cm**

## Effortless cutting – simple setup

**Integrated 5 cm cutting guides** enable precise length adjustment of the 1 m duct. The **17 mm wall thickness** allows easy cutting with a standard utility knife.

# 2x

## faster installation

ARIA ADURO is **up to 9 times lighter** than traditional metal duct systems. Lightweight construction **simplifies installation in walls** and suspended ceilings – **reducing installation time by up to 50%**.

# 2x

## lower airflow resistance compared to flexible ducting

Rigid construction with **smooth internal surface eliminates deformation during installation** and significantly reduces airflow resistance. **Up to twice lower resistance** compared to flexible ducts – ensuring quieter operation and lower energy consumption.



## Proven solution: OneClick® technology

Based on the proven OneClick® system used in HEATPEX ARIA air distribution systems. **Fast, secure and tool-free connection of ARIA ADURO components.**



# ARIA ADURO system components

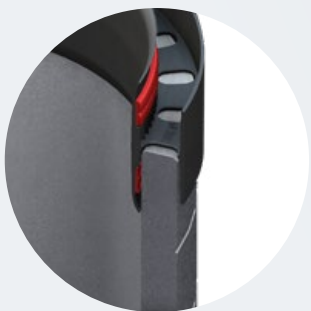

**Connector**

Push-fit connector with **integrated gasket**. **Low-profile design** does not increase overall installation diameter. Inspection openings indicate correct engagement and secure connection.



**Mounting bracket with clamp**

Bracket with integrated clamp for secure duct fixing.

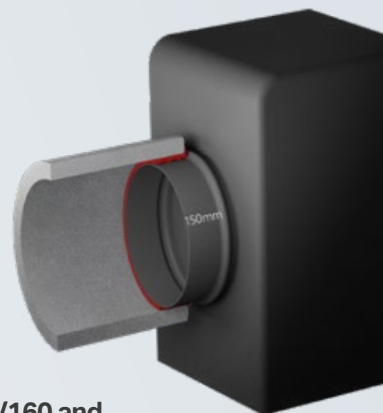

**150/160 and 180/200 adapters**

Adapters for connection of Ø 150 and Ø 180 recuperator spigots to Ø 160 and Ø 200 ADURO ducts.



**45° elbow**

Rigid 45° elbow for directional changes.



**Ducts**

**1 m rigid duct sections (single-piece construction).** Manufactured as monolithic elements for increased strength and reduced risk of damage. **3 diameters.**



**Reducer**

for Ø 125 / 160 / 200 mm systems.



**Tee**

T-branch fitting for system branching.



**Damper**

Manual airflow control damper.

# ARIA ADURO system components and accessories

ARIA ADURO system components		Diameter		Length mm	Material	Class tightness	Number catalogue
		internal	external				
		mm	mm				
<b>Pipe 1 m</b>		125	159	1000	EPS	ATC1	52912500100T
		160	194				52916000100T
		200	234				52920000100T
<b>Bend 45°</b>		125	159	213	EPS	ATC1	52912590100T
		160	194	226			52916090100T
		200	234	240			52920090100T
<b>Tee</b>		125	159	380	EPS	ATC1	52912580100W
		160	194				52916080100T
		200	234				52920080100T
<b>Damper</b>		125	159	250	EPS, galvanized steel	ATC1	52912560100W
		160	194				52916060100W
		200	234				52920060100W
<b>Connector</b>		125		70	PP, EPDM	ATC1	52912570100W
		160					52916070100W
		200					52920070100W
<b>Reducer</b>		125/160/200		167	EPS	ATC1	52010200100T
<b>Mounting bracket</b>		125/160/200		300	PP, nylon	ATC1	52010100100W
<b>MVHR unit connection adapter</b>		150/160		40	EPDM	ATC1	52011600100T
		180/200		40	EPDM	ATC1	52011700100T

ARIA ADURO system accessories		Diameter	Length	Material	Number catalogue
		mm	mm		
<b>Flexible duct silencer</b>		125	1000	Aluminum-polyester jacket, galvanized steel, EPDM gaskets, glass wool insulation	52010300100T
		160			52010400100T
		200			52010500100T
<b>Air intake / outlet grille - hooded</b>		125	-	Stainless steel	52010600100T
		160			52010700100T
		200			52010800100T
<b>Air intake / outlet grille - flat</b>		125	-	Stainless steel	52010900100T
		160			52011000100T
		200			52011100100T

Need more  
information?



EMAIL

[sales@heatpex.pl](mailto:sales@heatpex.pl)

OR VISIT

> [heatpex.pl](http://heatpex.pl)

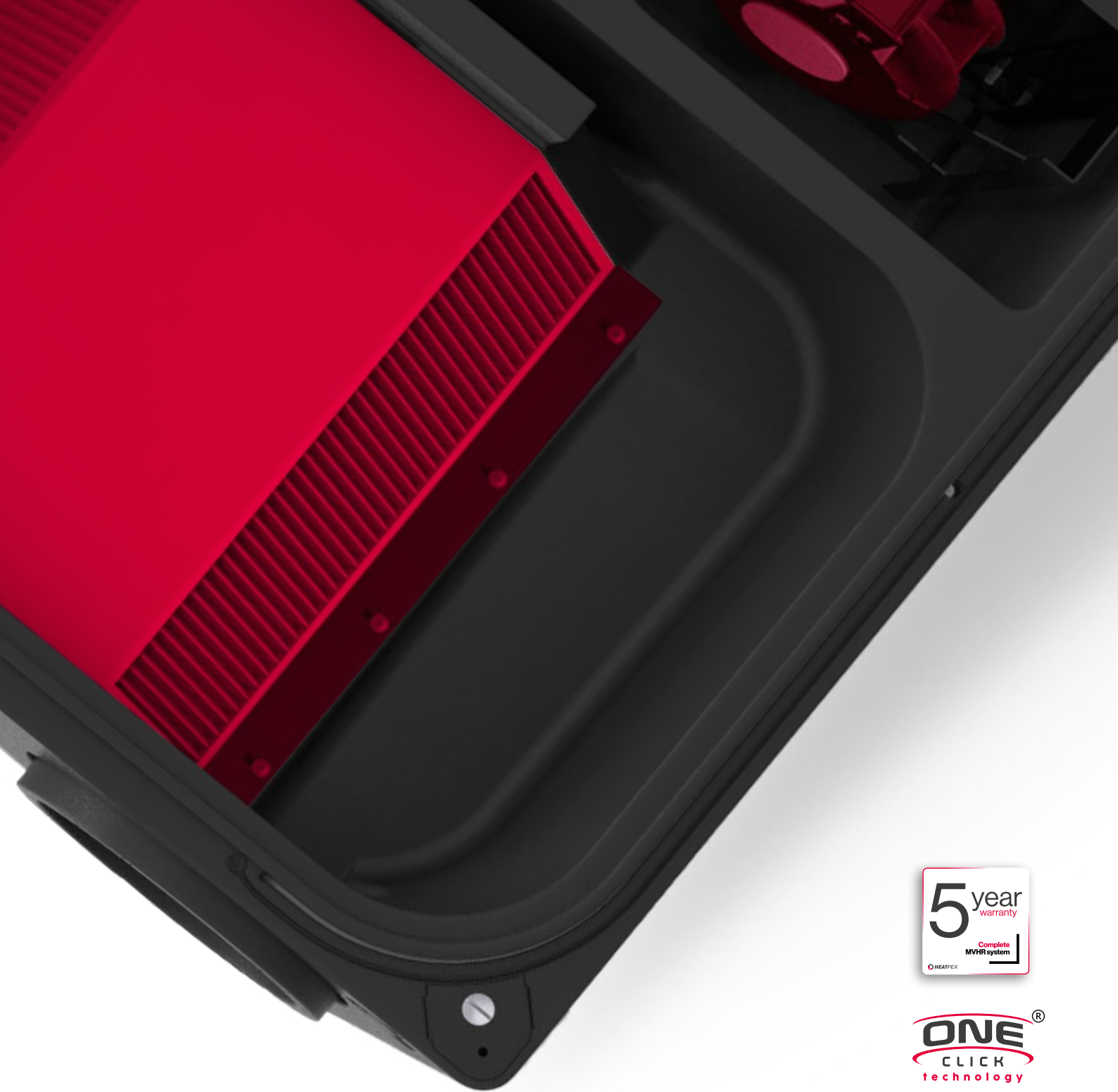

> [heatpex.pl](http://heatpex.pl)

**Heatpex Sp. z o.o.** Chrzanowskiego 11, 80-278 Gdańsk, Poland  
tel. +48 661 693 697, e-mail: [sales@heatpex.pl](mailto:sales@heatpex.pl)

